

TH3 TIRE HANDLER *C/W T3C100LP-29*



WBM Tire Handlers are designed to safely and efficiently handle OTR tires. The TH3 is a fully integrated, turnkey rough terrain / short wheel base tire handler; ideal for underground mines, construction sites and mobile tire service (12:00R24 – 29.5R29). Based on Sellick STM70 carrier machine.

FEATURES & BENEFITS

- 3 wheel hydrostatic drive for infinitely variable speed from 0 to 7 mph / 11 kmph
- Rear wheel steer offers extremely good maneuverability; machine can turn within its own length
- Kohler - Tier 4 final compliant engine – no DEF required provides low emissions and very low fuel consumption
- Compact 8' fork lift mast with positive down pressure allows tire manipulator to be used to break beads on tire / rim assembly for in pit / shop service
- 90° / right angle stack capability
- Hydraulically extending stabilizer's ensure safe and efficient handling of wheel assemblies
- Hydraulic extension / retraction of the integrally side-shifting mast assembly allows attachment to be positioned with machine static for precision control of the wheel assembly
- Fully certified ROPS / FOPS cab guard and seat belt protects the operator in the event of a rollover or falling debris

Continued on next page >>

TH3 FEATURES AND DIMENSIONS

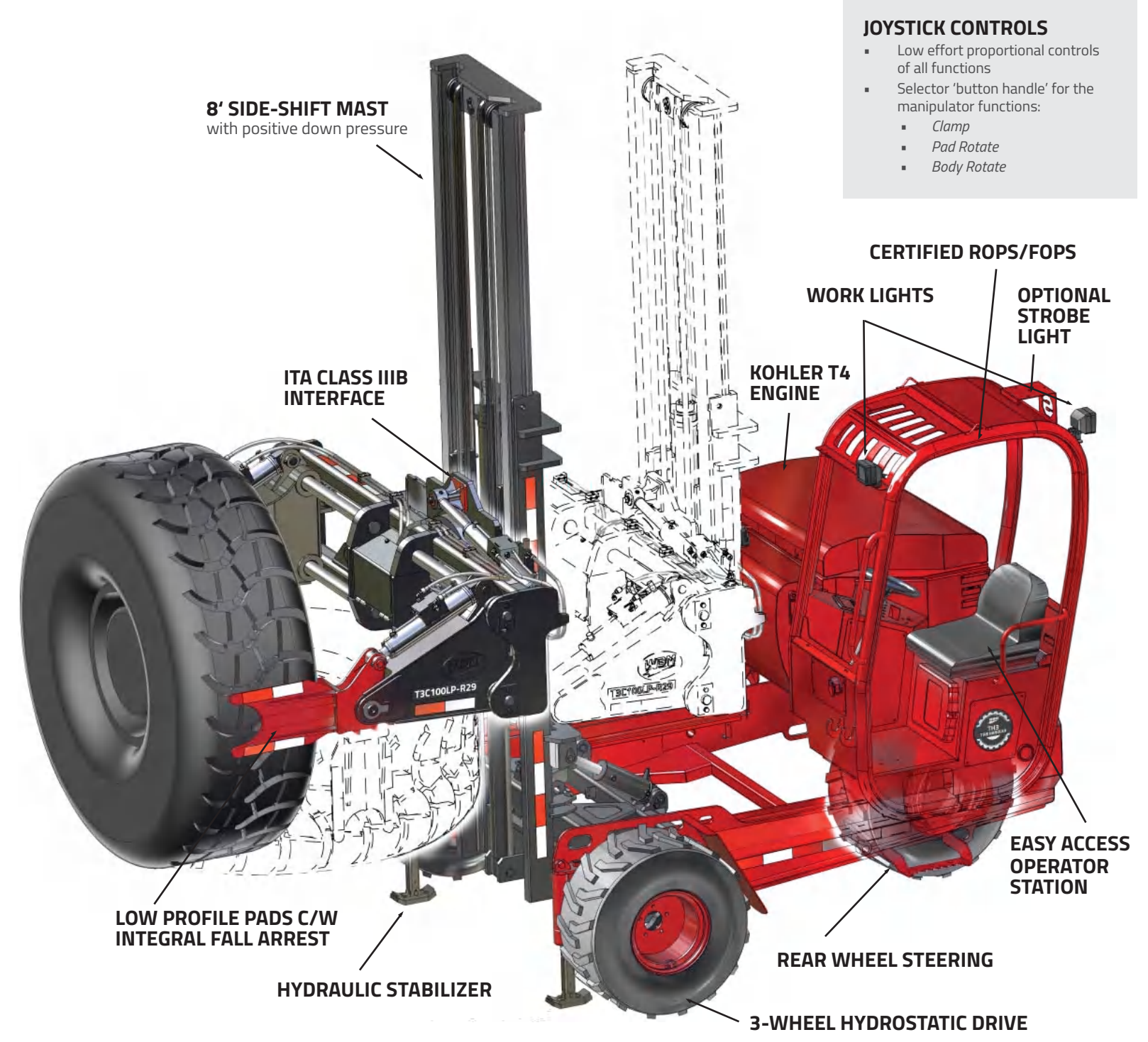
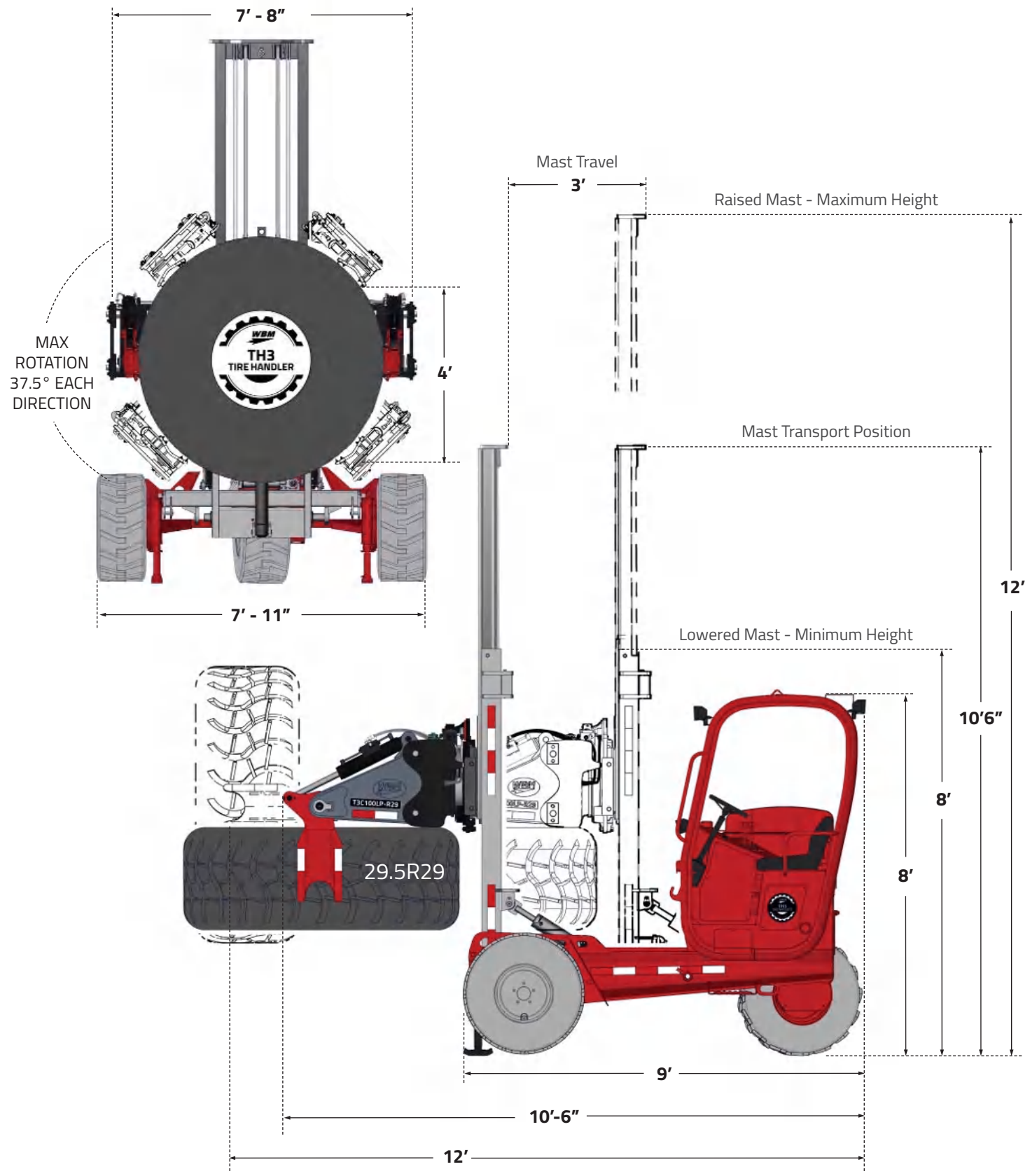

- JOYSTICK CONTROLS**
- Low effort proportional controls of all functions
 - Selector 'button handle' for the manipulator functions:
 - Clamp
 - Pad Rotate
 - Body Rotate

TH3 & T3C100LP-29 SPECIFICATIONS

MACHINE SPECIFICATIONS 100-710-0000

Rated Capacity <i>(at center of tire pad)</i>	3,000lb / 2200lb at full lift
Max Lift Height * T3 Level	96"
Gross Vehicle Weight	8,650 lbs (3,930 Kg) <i>including T3C100LP-29</i>
Engine	Kohler T4 56hp @ 2,200rpm
Drive	3 wheel drive - hydrostatic
Tires	10 - 16.5" all terrain (10 ply)
Max Speed	7 mph/ 11kmph
Ground Clearance	12"
Grade Ability	30%
Turn Radius / Right Angle Stack	85.5"/ 157"

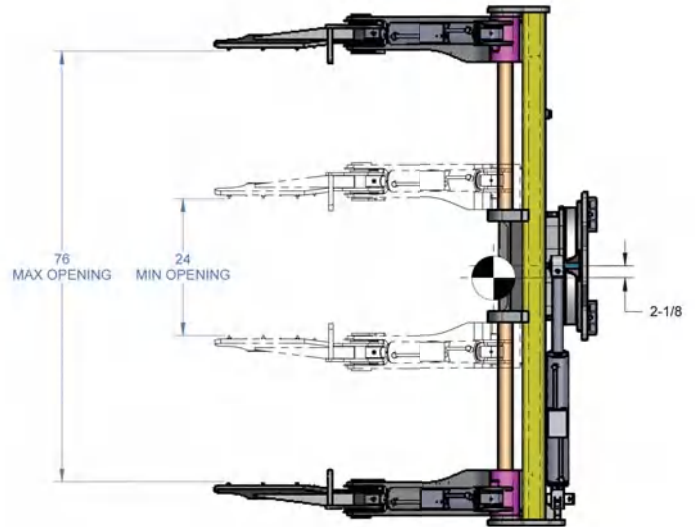

T3C100LP-R29 SPECIFICATIONS 176-722-0000

Machine Interface	ITA IIIB Carriage – Hook-on Mount
Integral Side-Shift Carriage	Machine Mast - 6" Max.
Rotation of Main Body	Heavy Duty Cylinder Driven 75° Rotation
Manipulator Arms	Telescopic - Slider
Controls	Push button handle on aux control; diverts oil for extra functions
Hydraulic System	Integral 4-Function Selector Valve - 10 - 20gpm @ 3000psi
Tire Pad Rotation	Heavy Duty Cylinder Driven 100° Rotation
Tire Pads	Concave – Low Profile
Fall Arrest Arms	N/A - Integral
Maximum Opening of Arms	76" / 1930 mm
Minimum Closing of Arms	24" / 610 mm
Weight Tire Handler	Est. 1,950 lbs / 885 Kg <i>*ITA mount</i>
Reach	Standard Grip Arm - 61" / 1550 mm @ max open / close
Tire Size Handling Range	Up to 29.5R29 (35/65R33* <i>depending on model</i>)

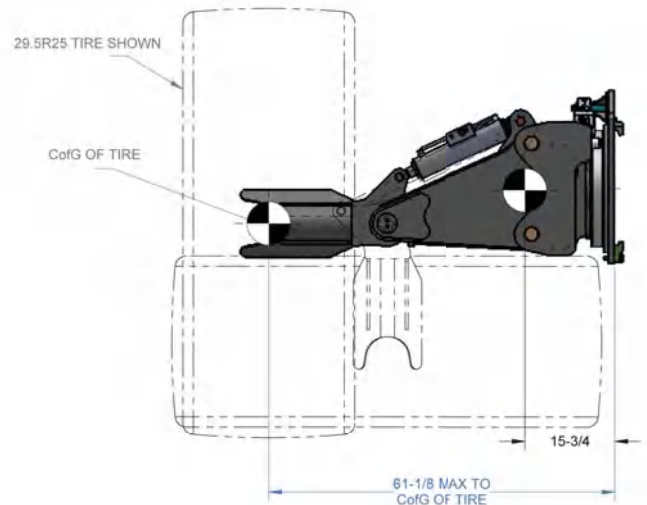

OPTIONAL EQUIPMENT

- ITA class IIIB carriage allows machine to be used with fork tines as a fork lift in operations that require versatility / multi-purpose functionality
- Central lubrication
- Extra lights
- Camera

Last revised: July 2018